



# SERVICE YOU CAN TRUST

**Double Width Tower**  
2.5m Long x 1.45m Wide

**Working Height**  
3.2m

**Platform Height**  
1.2m

## Tower Components

Item	Description	Quantity
1	150mm Locking Caster	4
2	Adjustable Leg 500mm	4
3	1m 4 Rung Frame	0
4	1.5m 6 Rung Frame	0
5	2m 8 Rung Frame	2
6	2.5m Trapdoor Platform	1
7	2.5m Fixed Platform	1
8	2.5m Horizontal Brace	6
9	2.7m Diagonal Brace	2
10	Complete Toe Board Set	1
11	S1 Stabiliser	0
12	S2 Stabiliser	0
13	Instruction Manual & EN1004:-1:2020 certificate of conformity	1

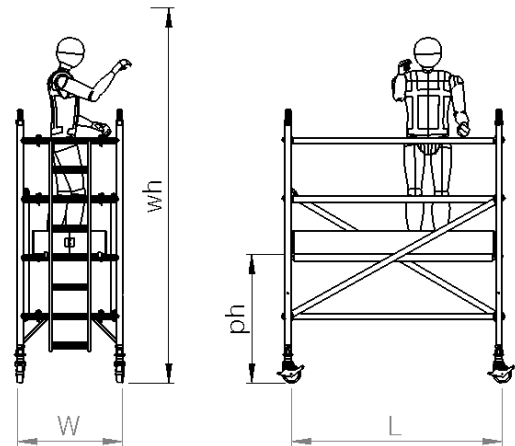
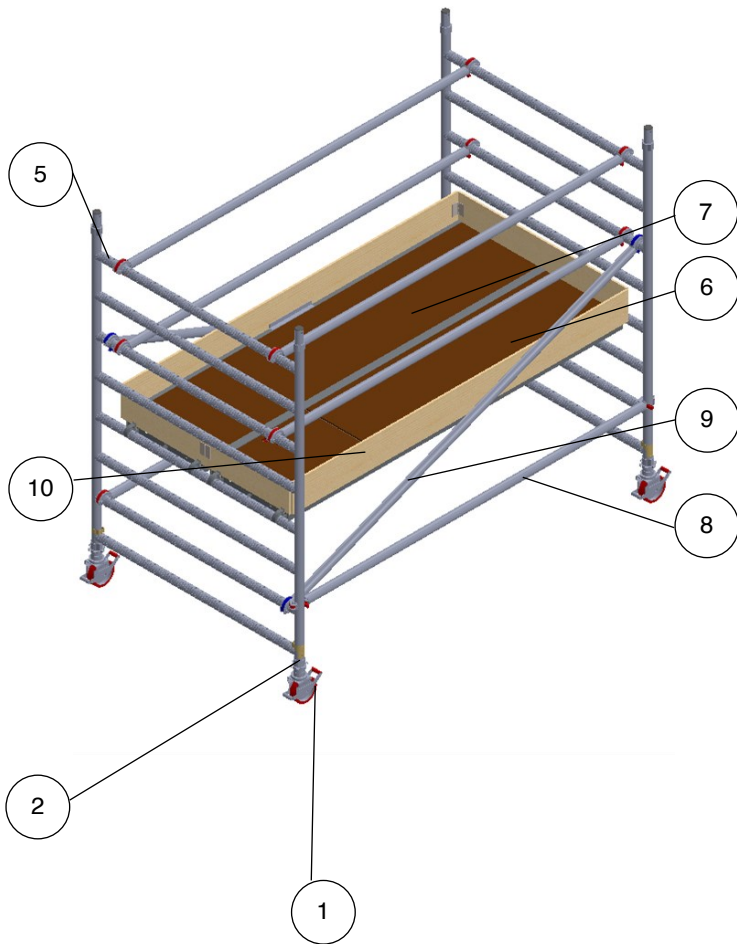

### Technical information:

Base Dimensions:	(L)2.5m X (W)1.45m
Maximum Platform Height (ph):	1.2m
Maximum Working Height (wh):	3.2m
Maximum Working Load Per Platform:	275kg
Maximum Working Load Per Tower: (including tower weight)	950kg
Weight:	97.4kg

Mr Plant Hire  
120 Hertford Road Enfield  
London EN3 5AX

☎ 020 8351 3434

✉ info@mrplanthire.co.uk





# SERVICE YOU CAN TRUST

<b>Double Width Tower</b> 2.5m Long x 1.45m Wide	<b>Working Height</b> 3.7m	<b>Platform Height</b> 1.7m
---	-------------------------------	--------------------------------

## Tower Components

Item	Description	Quantity
1	150mm Locking Caster	4
2	Adjustable Leg 500mm	4
3	1m 4 Rung Frame	2
4	1.5m 6 Rung Frame	2
5	2m 8 Rung Frame	0
6	2.5m Trapdoor Platform	1
7	2.5m Fixed Platform	1
8	2.5m Horizontal Brace	6
9	2.7m Diagonal Brace	3
10	Complete Toe Board Set	1
11	S1 Stabiliser	0
12	S2 Stabiliser	0
13	Instruction Manual & EN1004:-1:2020 certificate of conformity	1

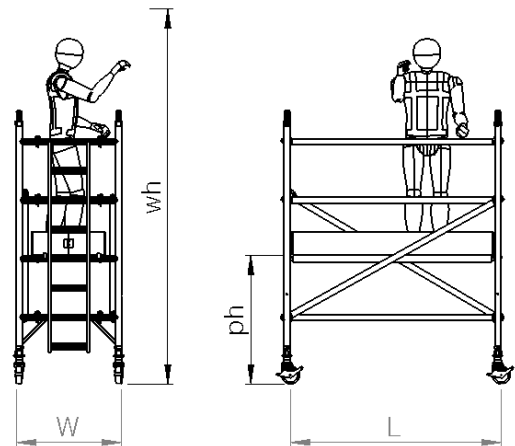
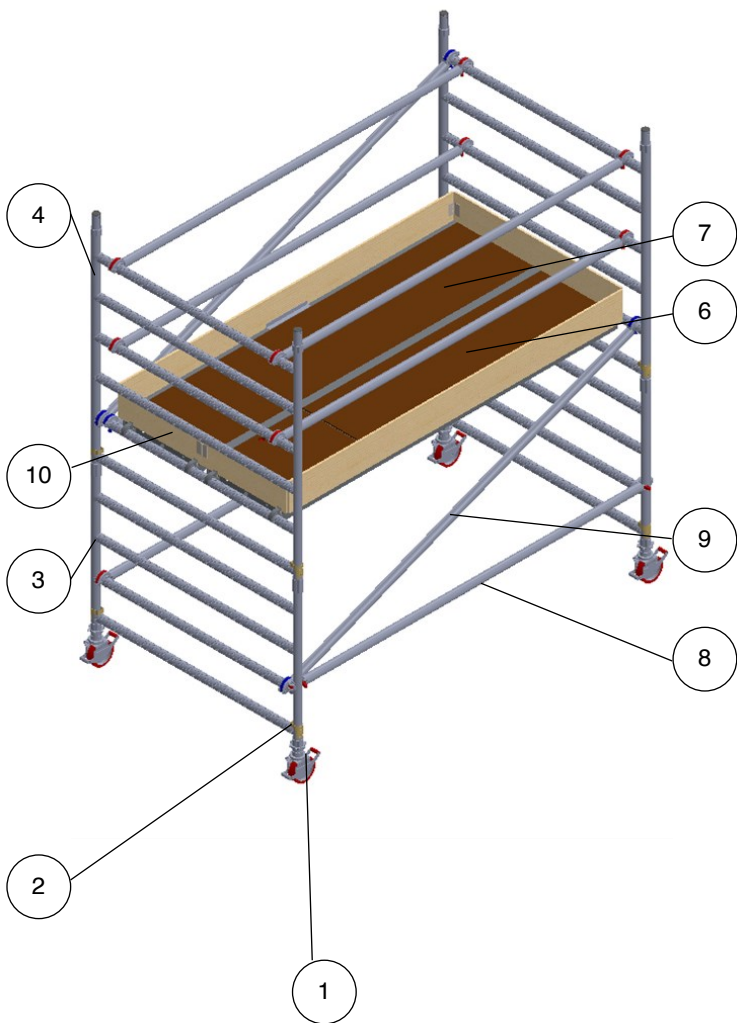

### Technical information:

Base Dimensions:	(L)2.5m X (W)1.45m
Maximum Platform Height (ph):	1.7m
Maximum Working Height (wh):	3.7m
Maximum Working Load Per Platform:	275kg
Maximum Working Load Per Tower: (including tower weight)	950kg
Weight:	105.3kg

<b>Double Width Tower</b> 2.5m Long x 1.45m Wide	<b>Working Height</b> 4.2m	<b>Platform Height</b> 2.2m
---	-------------------------------	--------------------------------

## Tower Components

Item	Description	Quantity
1	150mm Locking Caster	4
2	Adjustable Leg 500mm	4
3	1m 4 Rung Frame	2
4	1.5m 6 Rung Frame	0
5	2m 8 Rung Frame	2
6	2.5m Trapdoor Platform	1
7	2.5m Fixed Platform	1
8	2.5m Horizontal Brace	6
9	2.7m Diagonal Brace	3
10	Complete Toe Board Set	1
11	S1 Stabiliser	4
12	S2 Stabiliser	0
13	Instruction Manual & EN1004:-1:2020 certificate of conformity	1

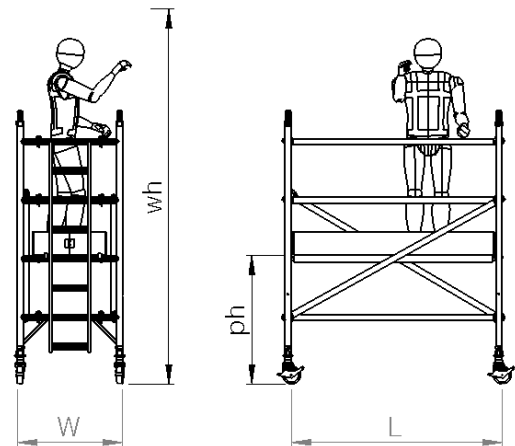
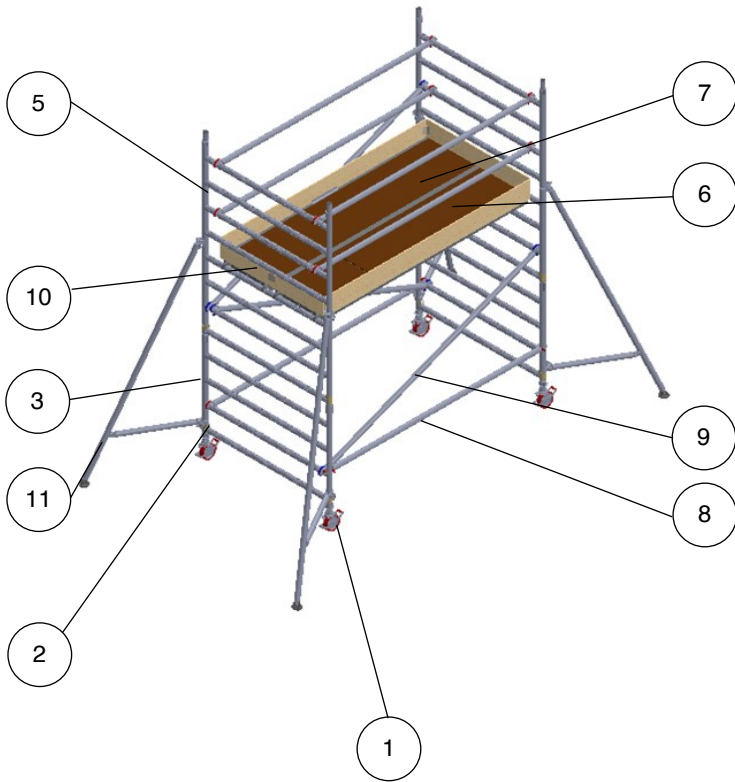

### Technical information:

Base Dimensions:	(L)2.5m X (W)1.45m
Maximum Platform Height (ph):	2.2m
Maximum Working Height (wh):	4.2m
Maximum Working Load Per Platform:	275kg
Maximum Working Load Per Tower: (including tower weight)	950kg
Weight:	125.6kg



# SERVICE YOU CAN TRUST

<b>Double Width Tower</b> 2.5m Long x 1.45m Wide	<b>Working Height</b> 4.7m	<b>Platform Height</b> 2.7m
---	-------------------------------	--------------------------------

## Tower Components

Item	Description	Quantity
1	150mm Locking Caster	4
2	Adjustable Leg 500mm	4
3	1m 4 Rung Frame	0
4	1.5m 6 Rung Frame	1
5	2m 8 Rung Frame	1
6	2.5m Trapdoor Platform	1
7	2.5m Fixed Platform	1
8	2.5m Horizontal Brace	6
9	2.7m Diagonal Brace	4
10	Complete Toe Board Set	1
11	S1 Stabiliser	4
12	S2 Stabiliser	0
13	Instruction Manual & EN1004:-1:2020 certificate of conformity	1

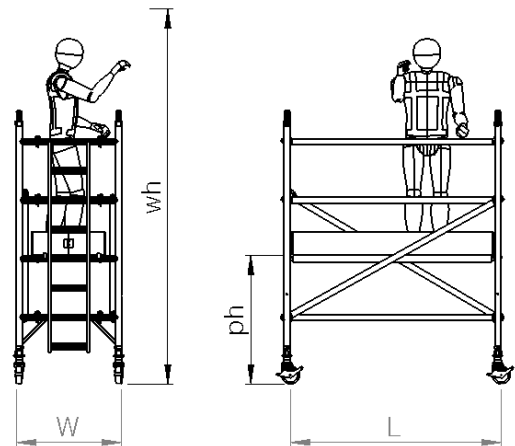
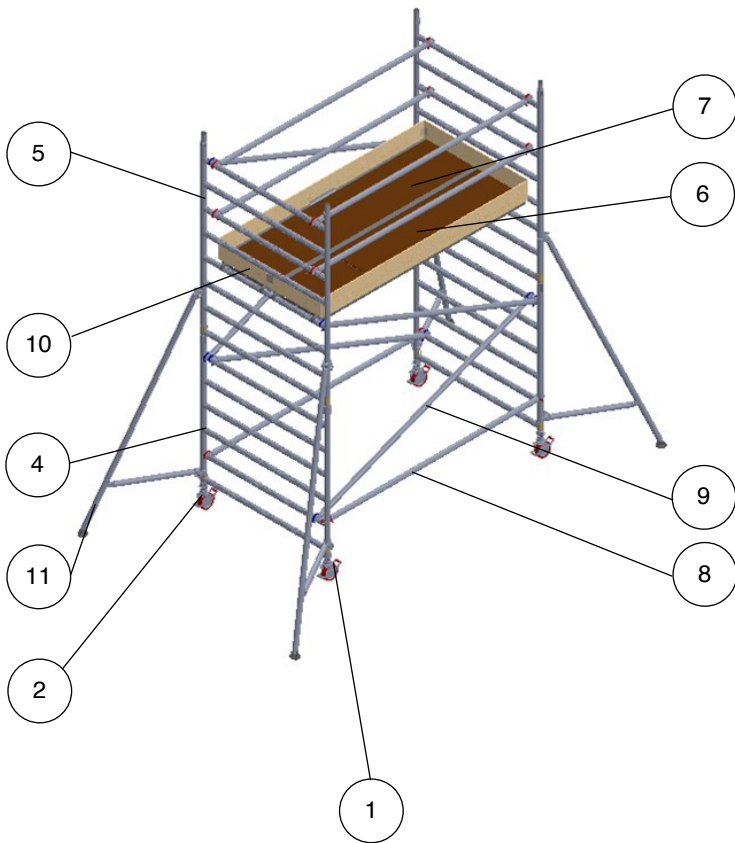

### Technical information:

Base Dimensions:	(L)2.5m X (W)1.45m
Maximum Platform Height (ph):	2.7m
Maximum Working Height (wh):	4.7m
Maximum Working Load Per Platform:	275kg
Maximum Working Load Per Tower: (including tower weight)	950kg
Weight:	132.2kg

Mr Plant Hire  
120 Hertford Road Enfield  
London EN3 5AX

☎ 020 8351 3434  
✉ info@mrplanthire.co.uk





# SERVICE YOU CAN TRUST

<b>Double Width Tower</b> 2.5m Long x 1.45m Wide	<b>Working Height</b> 5.2m	<b>Platform Height</b> 3.2m
---	-------------------------------	--------------------------------

## Tower Components

Item	Description	Quantity
1	150mm Locking Caster	4
2	Adjustable Leg 500mm	4
3	1m 4 Rung Frame	0
6	1.5m 6 Rung Frame	0
7	2m 8 Rung Frame	4
9	2.5m Trapdoor Platform	2
10	2.5m Fixed Platform	1
11	2.5m Horizontal Brace	10
12	2.7m Diagonal Brace	5
13	Complete Toe Board Set	1
14	S1 Stabiliser	4
15	S2 Stabiliser	0
16	Instruction Manual & EN1004:-1:2020 certificate of conformity	1

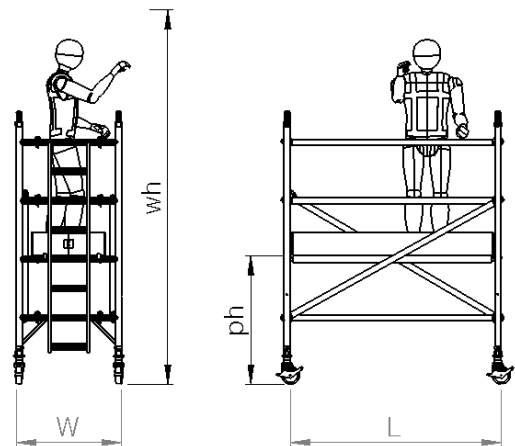
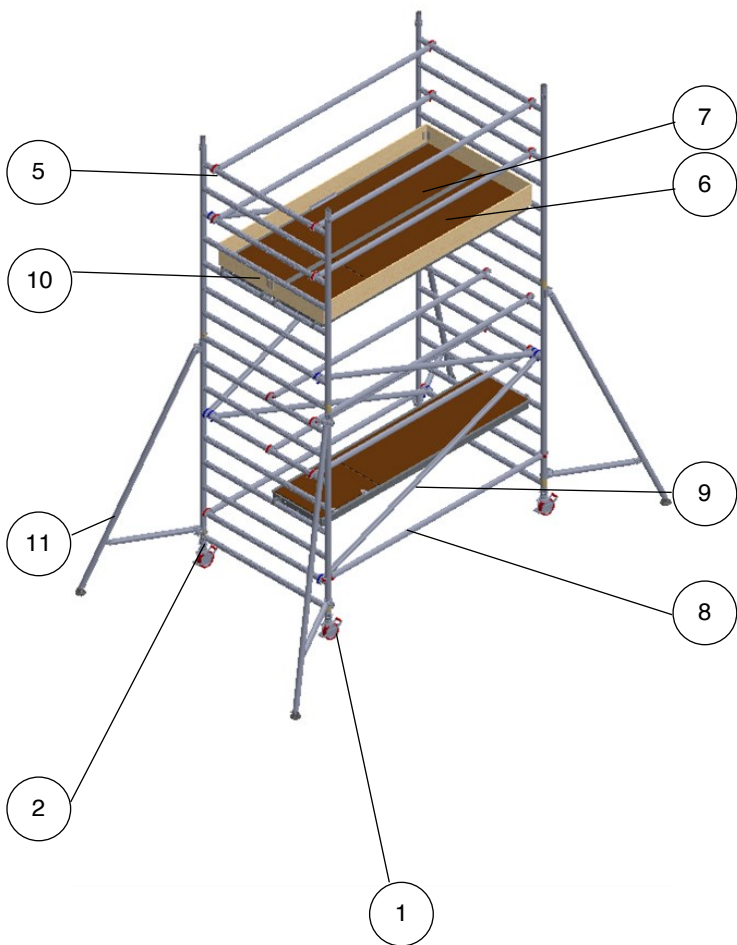

### Technical information:

Base Dimensions:	(L)2.5m X (W)1.45m
Maximum Platform Height (ph):	3.2m
Maximum Working Height (wh):	5.2m
Maximum Working Load Per Platform:	275kg
Maximum Working Load Per Tower: (including tower weight)	950kg
Weight:	164kg

Mr Plant Hire  
120 Hertford Road Enfield  
London EN3 5AX

☎ 020 8351 3434  
✉ info@mrplanthire.co.uk

BS 8620:2016  
TM1005  
testandresearch.org



# SERVICE YOU CAN TRUST

**Double Width Tower**  
2.5m Long x 1.45m Wide

**Working Height**  
5.7m

**Platform Height**  
3.7m

## Tower Components

Item	Description	Quantity
1	150mm Locking Caster	4
2	Adjustable Leg 500mm	4
3	1m 4 Rung Frame	2
4	1.5m 6 Rung Frame	2
5	2m 8 Rung Frame	2
6	2.5m Trapdoor Platform	2
7	2.5m Fixed Platform	1
8	2.5m Horizontal Brace	10
9	2.7m Diagonal Brace	6
10	Complete Toe Board Set	1
11	S1 Stabiliser	4
12	S2 Stabiliser	0
13	Instruction Manual & EN1004:-1:2020 certificate of conformity	1

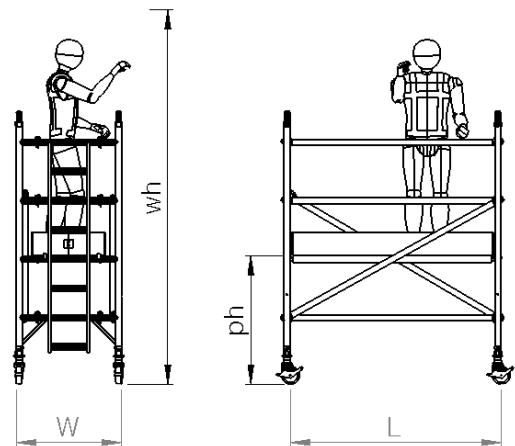
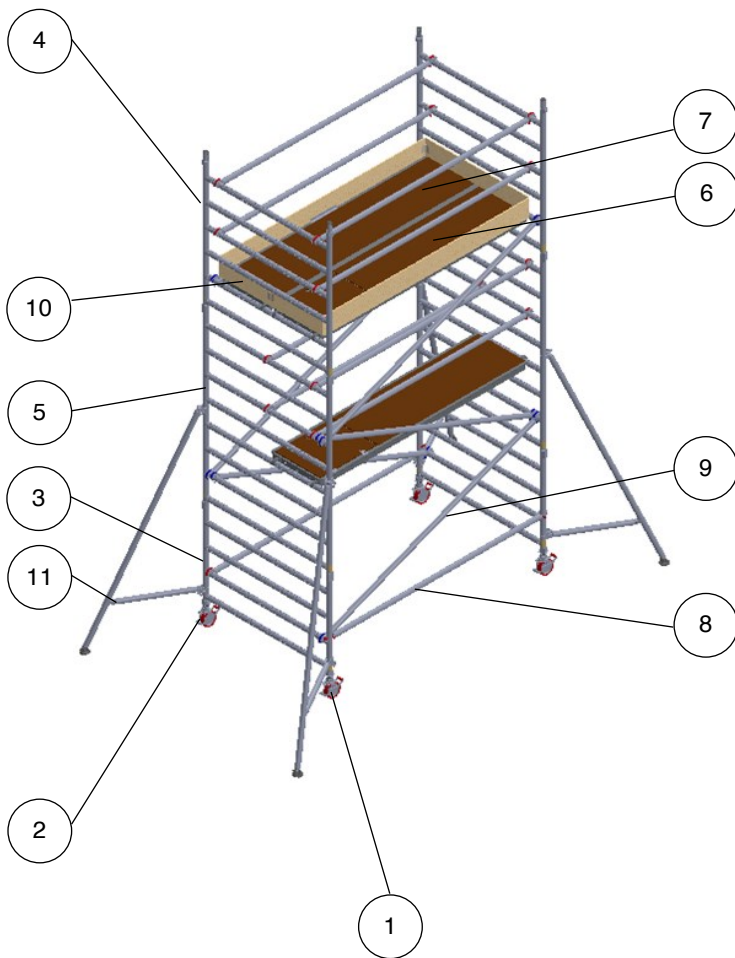

### Technical information:

Base Dimensions:	(L)2.5m X (W)1.45m
Maximum Platform Height (ph):	3.7m
Maximum Working Height (wh):	5.7m
Maximum Working Load Per Platform:	275kg
Maximum Working Load Per Tower: (including tower weight)	950kg
Weight:	171.9kg

Mr Plant Hire  
120 Hertford Road Enfield  
London EN3 5AX

☎ 020 8351 3434

✉ info@mrplanthire.co.uk



<b>Double Width Tower</b> 2.5m Long x 1.45m Wide	<b>Working Height</b> 6.2m	<b>Platform Height</b> 4.2m
---	-------------------------------	--------------------------------

## Tower Components

Item	Description	Quantity
1	150mm Locking Caster	4
2	Adjustable Leg 500mm	4
3	1m 4 Rung Frame	2
4	1.5m 6 Rung Frame	0
5	2m 8 Rung Frame	4
6	2.5m Trapdoor Platform	2
7	2.5m Fixed Platform	1
8	2.5m Horizontal Brace	10
9	2.7m Diagonal Brace	7
10	Complete Toe Board Set	1
11	S1 Stabiliser	4
12	S2 Stabiliser	0
13	Instruction Manual & EN1004:-1:2020 certificate of conformity	1

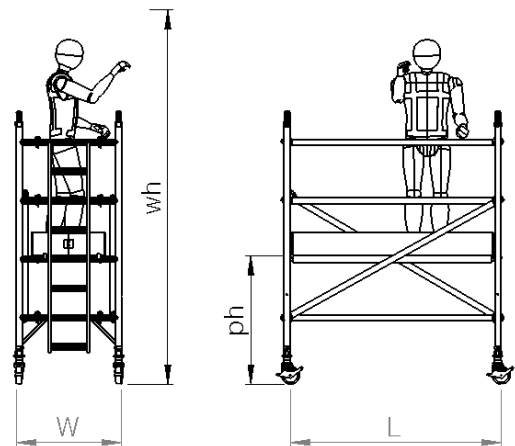
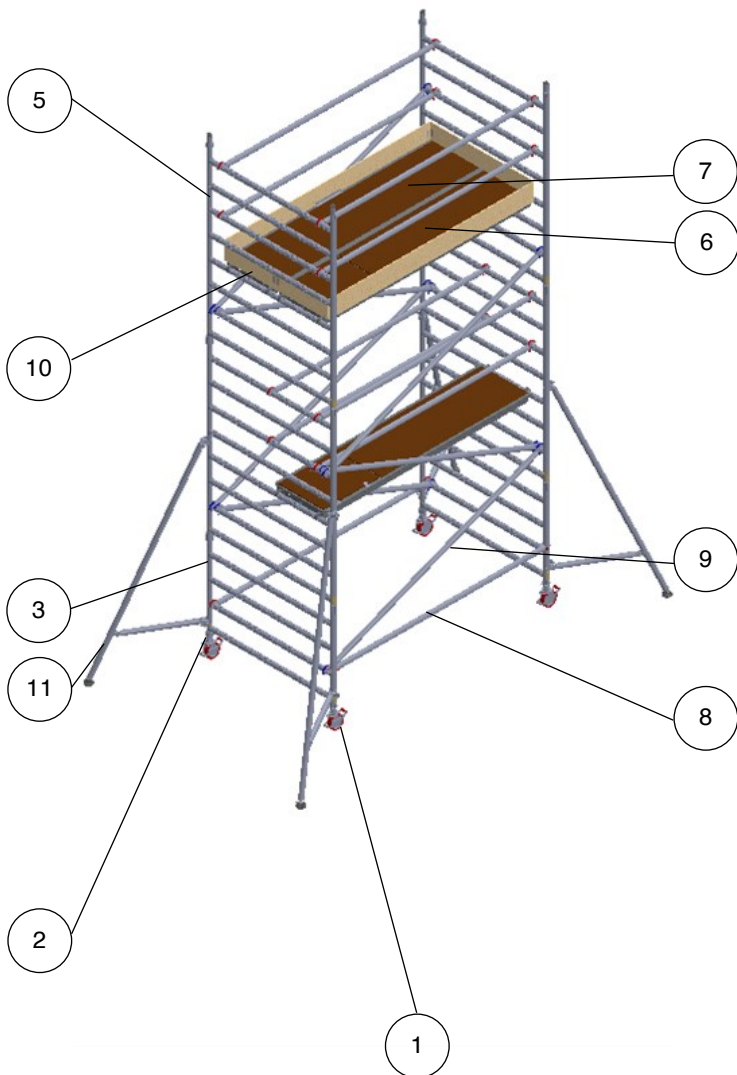

### Technical information:

Base Dimensions:	(L)2.5m X (W)1.45m
Maximum Platform Height (ph):	4.2m
Maximum Working Height (wh):	6.2m
Maximum Working Load Per Platform:	275kg
Maximum Working Load Per Tower: (including tower weight)	950kg
Weight:	178.2kg



# SERVICE YOU CAN TRUST

<b>Double Width Tower</b> 2.5m Long x 1.45m Wide	<b>Working Height</b> 6.7m	<b>Platform Height</b> 4.7m
---	-------------------------------	--------------------------------

## Tower Components

Item	Description	Quantity
1	150mm Locking Caster	4
2	Adjustable Leg 500mm	4
3	1m 4 Rung Frame	0
4	1.5m 6 Rung Frame	2
5	2m 8 Rung Frame	4
6	2.5m Trapdoor Platform	2
7	2.5m Fixed Platform	1
8	2.5m Horizontal Brace	10
9	2.7m Diagonal Brace	8
10	Complete Toe Board Set	1
11	S1 Stabiliser	4
12	S2 Stabiliser	0
13	Instruction Manual & EN1004:-1:2020 certificate of conformity	1

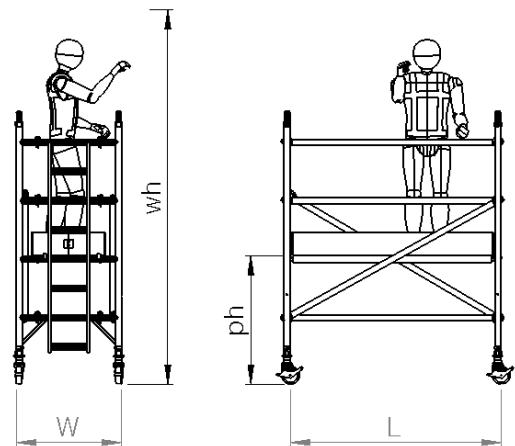
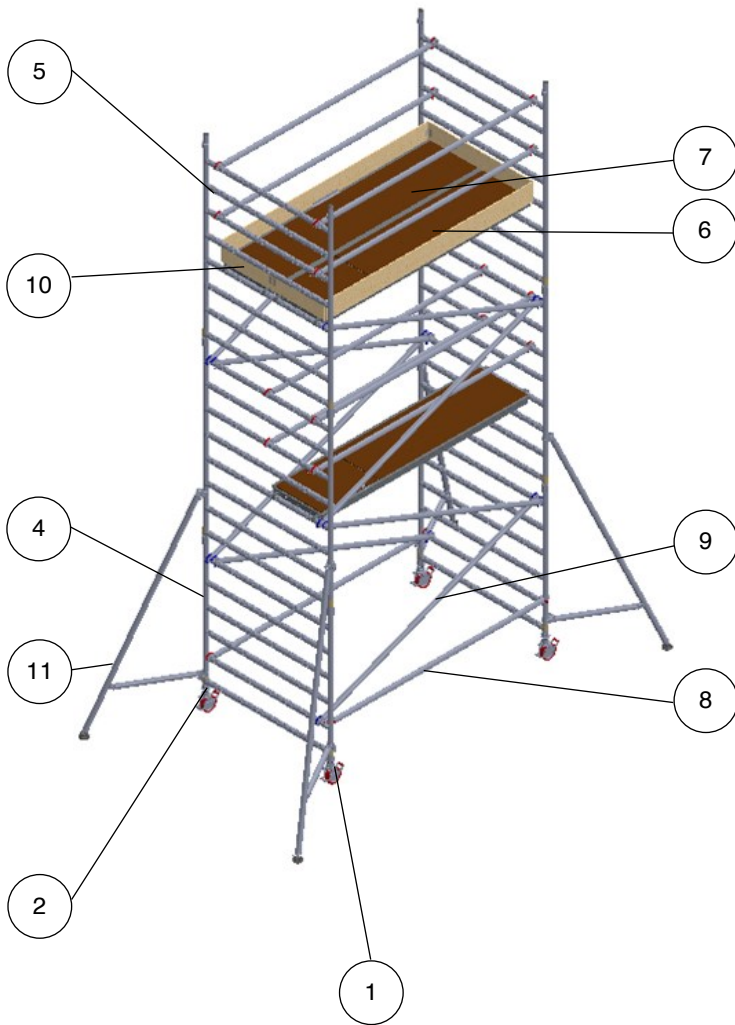

### Technical information:

Base Dimensions:	(L)2.5m X (W)1.45m
Maximum Platform Height (ph):	4.7m
Maximum Working Height (wh):	6.7m
Maximum Working Load Per Platform:	275kg
Maximum Working Load Per Tower: (including tower weight)	950kg
Weight:	184.8kg

Mr Plant Hire  
120 Hertford Road Enfield  
London EN3 5AX

☎ 020 8351 3434  
✉ info@mrplanthire.co.uk







# SERVICE YOU CAN TRUST

**Double Width Tower**  
2.5m Long x 1.45m Wide

**Working Height**  
7.2m

**Platform Height**  
5.2m

## Tower Components

Item	Description	Quantity
1	150mm Locking Caster	4
2	Adjustable Leg 500mm	4
3	1m 4 Rung Frame	0
4	1.5m 6 Rung Frame	0
5	2m 8 Rung Frame	3
6	2.5m Trapdoor Platform	3
7	2.5m Fixed Platform	1
8	2.5m Horizontal Brace	14
9	2.7m Diagonal Brace	9
10	Complete Toe Board Set	1
11	S1 Stabiliser	4
12	S2 Stabiliser	0
13	Instruction Manual & EN1004:-1:2020 certificate of conformity	1

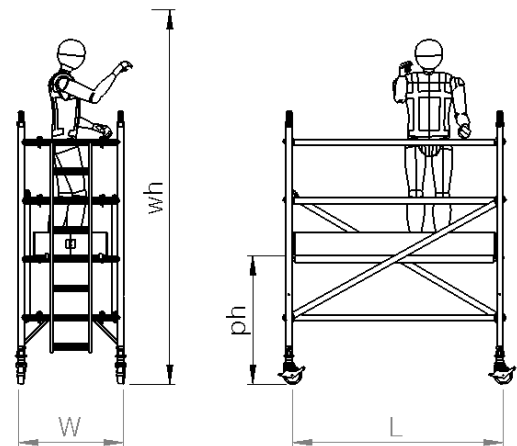
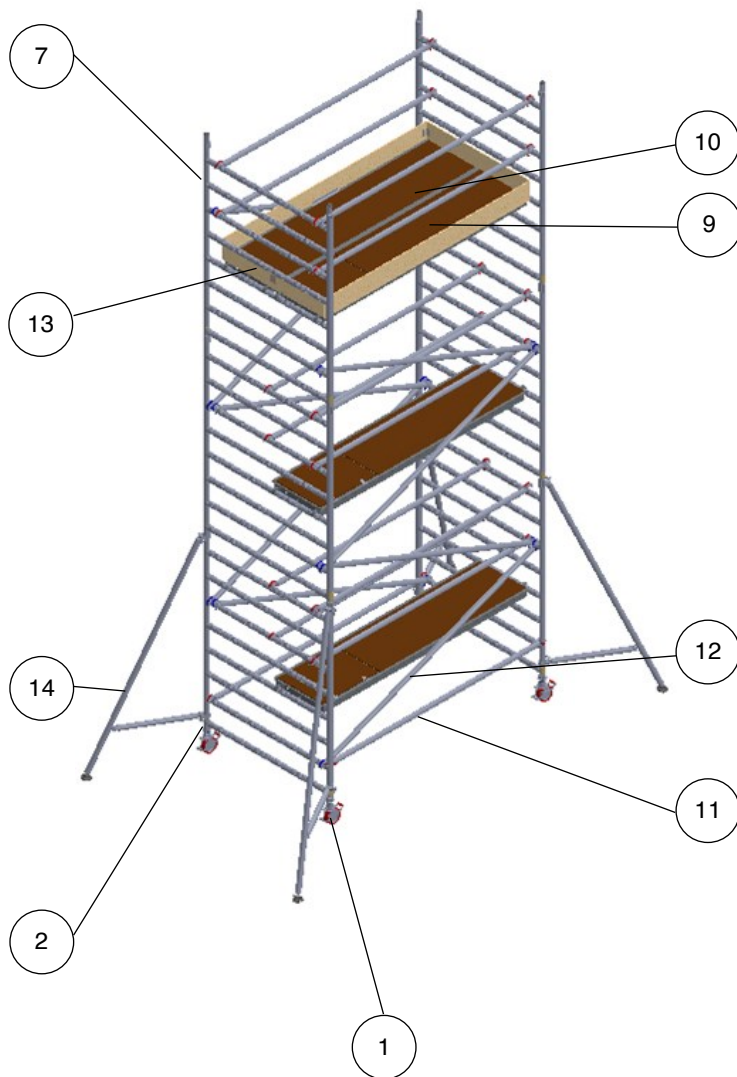

### Technical information:

Base Dimensions:	(L)2.5m X (W)1.45m
Maximum Platform Height (ph):	5.2m
Maximum Working Height (wh):	7.2m
Maximum Working Load Per Platform:	275kg
Maximum Working Load Per Tower: (including tower weight)	950kg
Weight:	216.6kg

Mr Plant Hire  
120 Hertford Road Enfield  
London EN3 5AX

☎ 020 8351 3434  
✉ info@mrplanthire.co.uk





# SERVICE YOU CAN TRUST

**Double Width Tower**  
2.5m Long x 1.45m Wide

**Working Height**  
7.7m

**Platform Height**  
5.7m

## Tower Components

Item	Description	Quantity
1	150mm Locking Caster	4
2	Adjustable Leg 500mm	4
3	1m 4 Rung Frame	2
4	1.5m 6 Rung Frame	2
5	2m 8 Rung Frame	4
6	2.5m Trapdoor Platform	3
7	2.5m Fixed Platform	1
8	2.5m Horizontal Brace	14
9	2.7m Diagonal Brace	10
10	Complete Toe Board Set	1
11	S1 Stabiliser	4
12	S2 Stabiliser	0
13	Instruction Manual & EN1004:-1:2020 certificate of conformity	1

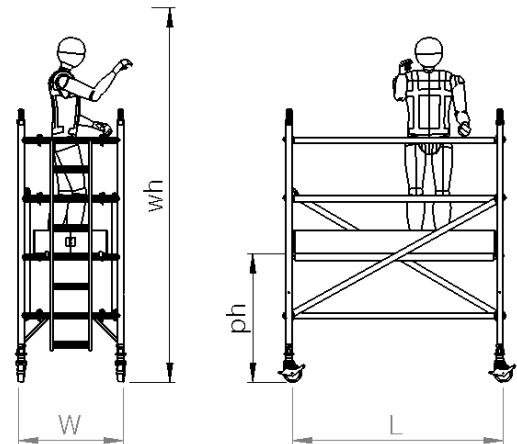
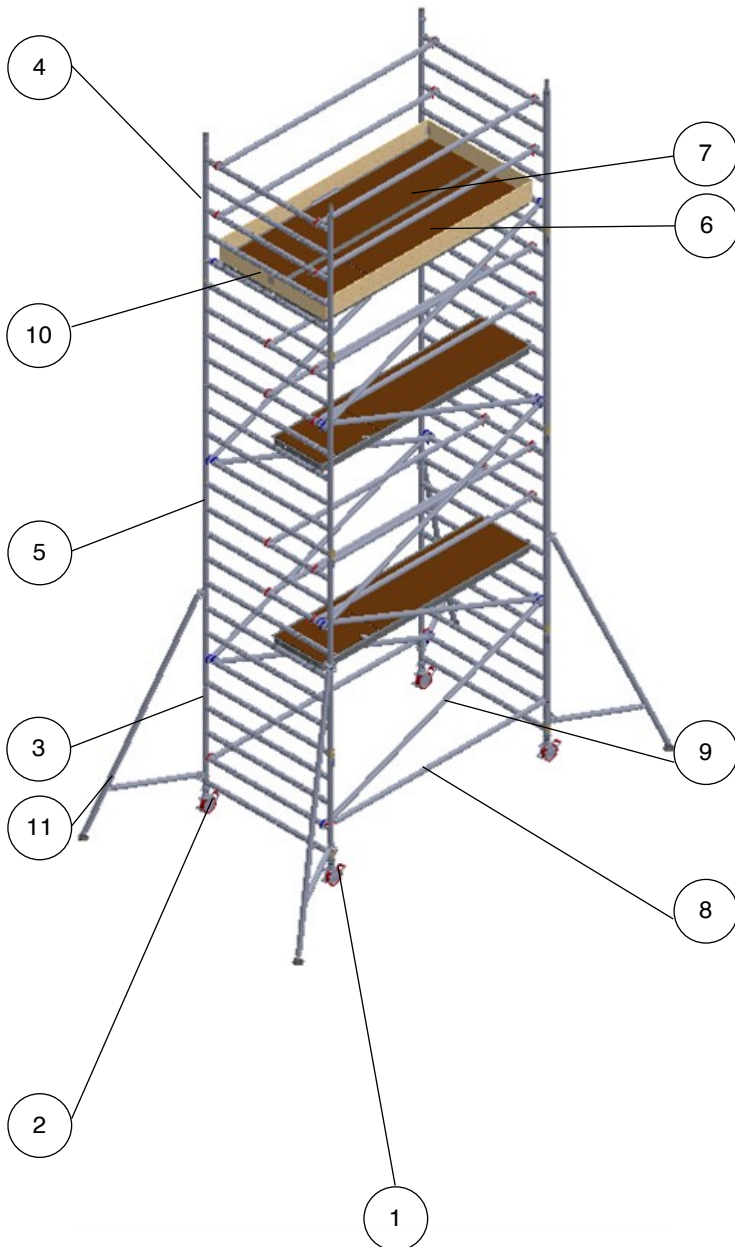

### Technical information:

Base Dimensions:	(L)2.5m X (W)1.45m
Maximum Platform Height (ph):	5.7m
Maximum Working Height (wh):	7.7m
Maximum Working Load Per Platform:	275kg
Maximum Working Load Per Tower: (including tower weight)	950kg
Weight:	224.5kg

Mr Plant Hire  
120 Hertford Road Enfield  
London EN3 5AX

☎ 020 8351 3434

✉ info@mrplanthire.co.uk



<b>Double Width Tower</b> 2.5m Long x 1.45m Wide	<b>Working Height</b> 8.2m	<b>Platform Height</b> 6.2m
---	-------------------------------	--------------------------------

## Tower Components

Item	Description	Quantity
1	150mm Locking Caster	4
2	Adjustable Leg 500mm	4
3	1m 4 Rung Frame	2
4	1.5m 6 Rung Frame	0
5	2m 8 Rung Frame	6
6	2.5m Trapdoor Platform	3
7	2.5m Fixed Platform	1
8	2.5m Horizontal Brace	14
9	2.7m Diagonal Brace	11
10	Complete Toe Board Set	1
11	S1 Stabiliser	4
12	S2 Stabiliser	0
13	Instruction Manual & EN1004:-1:2020 certificate of conformity	1

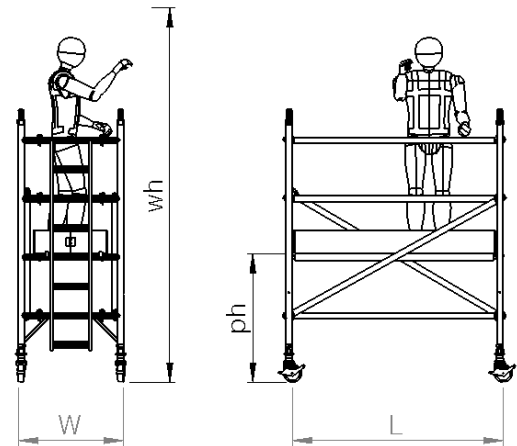
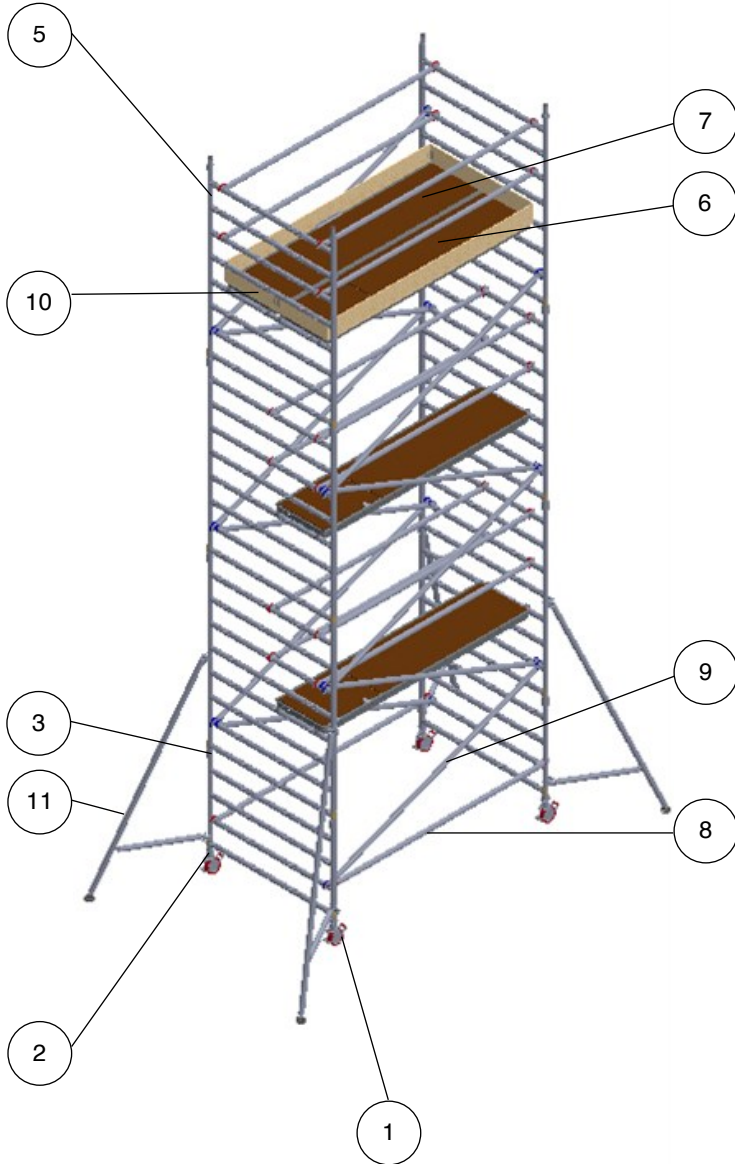

### Technical information:

Base Dimensions:	(L)2.5m X (W)1.45m
Maximum Platform Height (ph):	6.2m
Maximum Working Height (wh):	8.2m
Maximum Working Load Per Platform:	275kg
Maximum Working Load Per Tower: (including tower weight)	950kg
Weight:	230.8kg



# SERVICE YOU CAN TRUST

**Double Width Tower**  
2.5m Long x 1.45m Wide

**Working Height**  
8.7m

**Platform Height**  
6.7m

## Tower Components

Item	Description	Quantity
1	150mm Locking Caster	4
2	Adjustable Leg 500mm	4
3	1m 4 Rung Frame	0
4	1.5m 6 Rung Frame	2
5	2m 8 Rung Frame	6
6	2.5m Trapdoor Platform	3
7	2.5m Fixed Platform	1
8	2.5m Horizontal Brace	14
9	2.7m Diagonal Brace	12
10	Complete Toe Board Set	1
11	S1 Stabiliser	4
12	S2 Stabiliser	0
13	Instruction Manual & EN1004:-1:2020 certificate of conformity	1

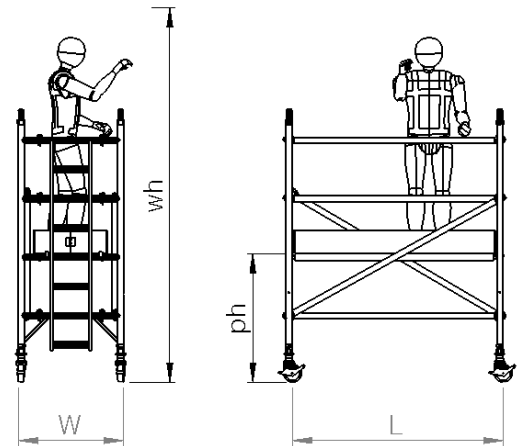
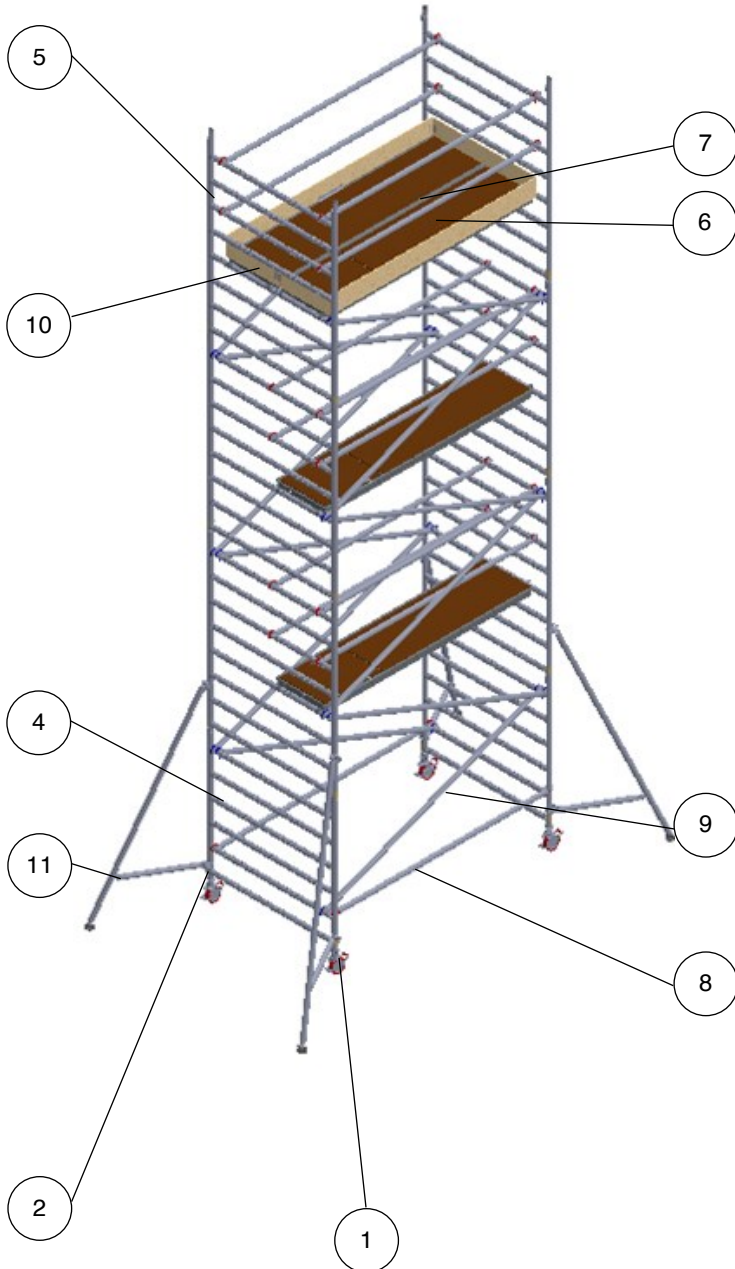

### Technical information:

Base Dimensions:	(L)2.5m X (W)1.45m
Maximum Platform Height (ph):	6.7m
Maximum Working Height (wh):	8.7m
Maximum Working Load Per Platform:	275kg
Maximum Working Load Per Tower: (including tower weight)	950kg
Weight:	237.4kg

Mr Plant Hire  
120 Hertford Road Enfield  
London EN3 5AX

☎ 020 8351 3434  
✉ info@mrplanthire.co.uk





# SERVICE YOU CAN TRUST

<b>Double Width Tower</b> 2.5m Long x 1.45m Wide	<b>Working Height</b> 9.2m	<b>Platform Height</b> 7.2m
---	-------------------------------	--------------------------------

## Tower Components

Item	Description	Quantity
1	150mm Locking Caster	4
2	Adjustable Leg 500mm	4
3	1m 4 Rung Frame	0
4	1.5m 6 Rung Frame	0
5	2m 8 Rung Frame	8
6	2.5m Trapdoor Platform	4
7	2.5m Fixed Platform	1
8	2.5m Horizontal Brace	18
9	2.7m Diagonal Brace	13
10	Complete Toe Board Set	1
11	S1 Stabiliser	4
12	S2 Stabiliser	0
13	Instruction Manual & EN1004:-1:2020 certificate of conformity	1

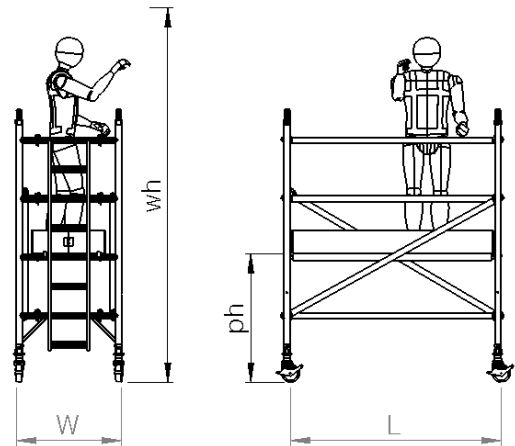
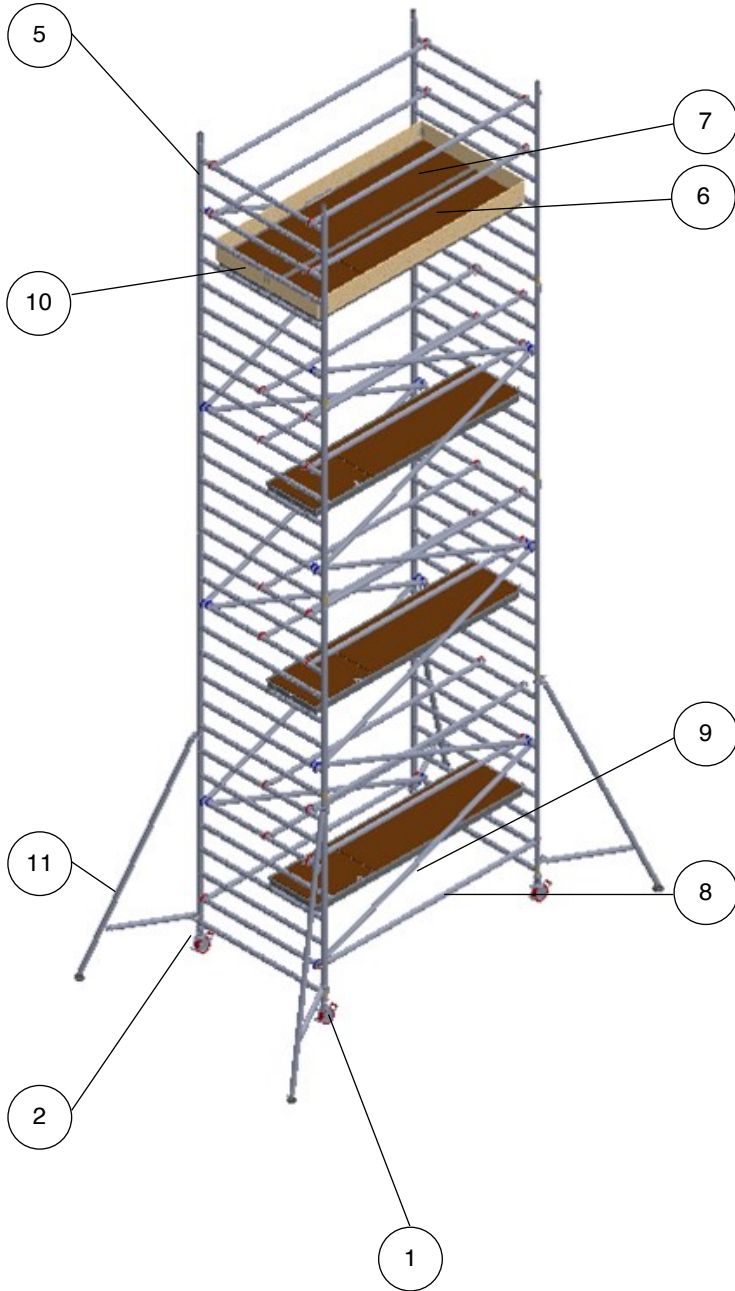

### Technical information:

Base Dimensions:	(L)2.5m X (W)1.45m
Maximum Platform Height (ph):	7.2m
Maximum Working Height (wh):	9.2m
Maximum Working Load Per Platform:	275kg
Maximum Working Load Per Tower: (including tower weight)	950kg
Weight:	269.2kg

Mr Plant Hire  
120 Hertford Road Enfield  
London EN3 5AX

☎ 020 8351 3434  
✉ info@mrplanthire.co.uk



<b>Double Width Tower</b> 2.5m Long x 1.45m Wide	<b>Working Height</b> 9.7m	<b>Platform Height</b> 7.7m
---	-------------------------------	--------------------------------

## Tower Components

Item	Description	Quantity
1	150mm Locking Caster	4
2	Adjustable Leg 500mm	4
3	1m 4 Rung Frame	2
4	1.5m 6 Rung Frame	2
5	2m 8 Rung Frame	6
6	2.5m Trapdoor Platform	4
7	2.5m Fixed Platform	1
8	2.5m Horizontal Brace	18
9	2.7m Diagonal Brace	14
10	Complete Toe Board Set	1
11	S1 Stabiliser	4
12	S2 Stabiliser	0
13	Instruction Manual & EN1004:-1:2020 certificate of conformity	1

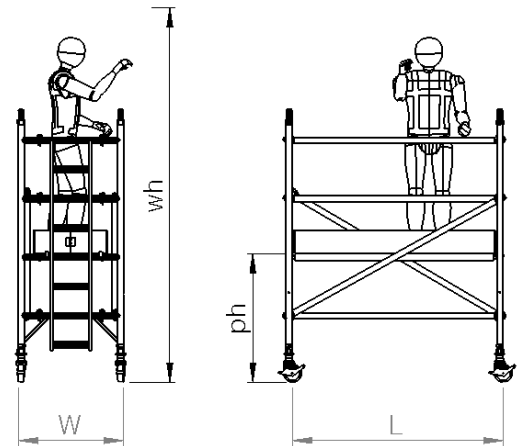
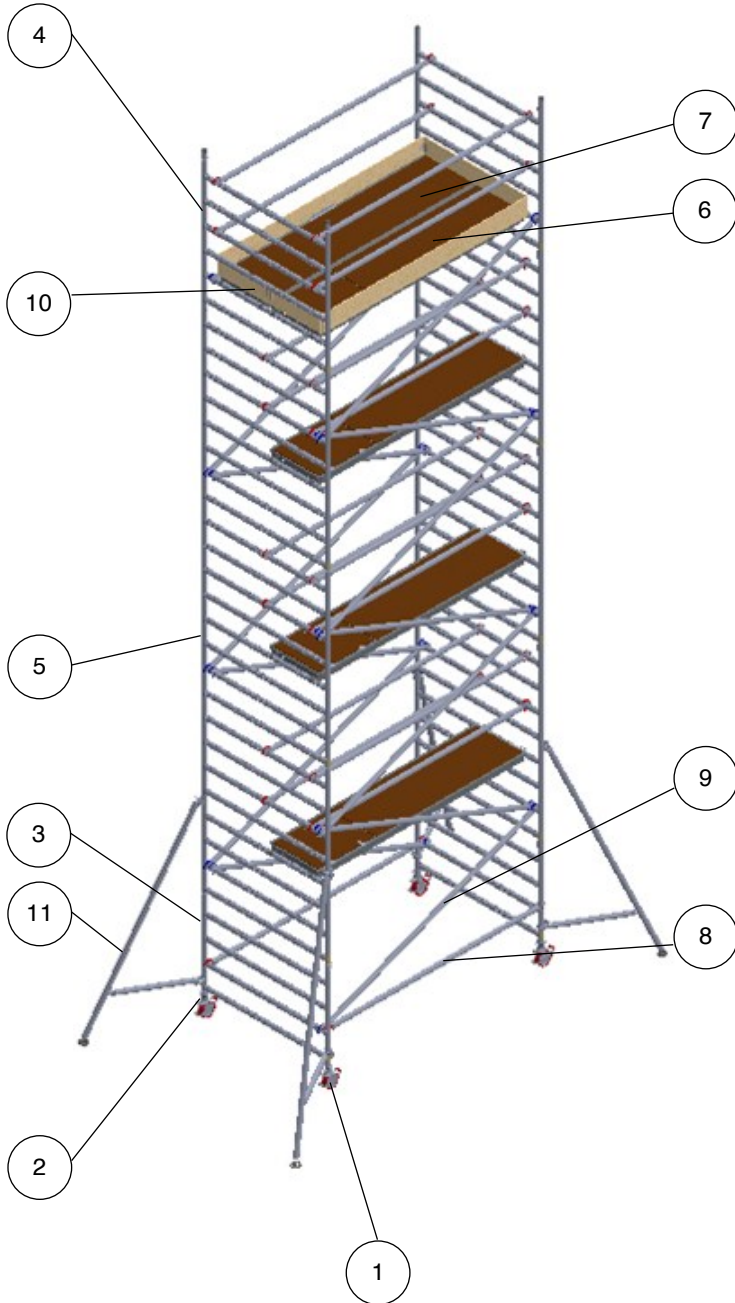

### Technical information:

Base Dimensions:	(L)2.5m X (W)1.45m
Maximum Platform Height (ph):	7.7m
Maximum Working Height (wh):	9.7m
Maximum Working Load Per Platform:	275kg
Maximum Working Load Per Tower: (including tower weight)	950kg
Weight:	277.1kg



# SERVICE YOU CAN TRUST

**Double Width Tower**  
2.5m Long x 1.45m Wide

**Working Height**  
10.2m

**Platform Height**  
8.2m

## Tower Components

Item	Description	Quantity
1	150mm Locking Caster	4
2	Adjustable Leg 500mm	4
3	1m 4 Rung Frame	2
4	1.5m 6 Rung Frame	0
5	2m 8 Rung Frame	8
6	2.5m Trapdoor Platform	4
7	2.5m Fixed Platform	1
8	2.5m Horizontal Brace	18
9	2.7m Diagonal Brace	15
10	Complete Toe Board Set	1
11	S1 Stabiliser	4
12	S2 Stabiliser	0
13	Instruction Manual & EN1004:-1:2020 certificate of conformity	1

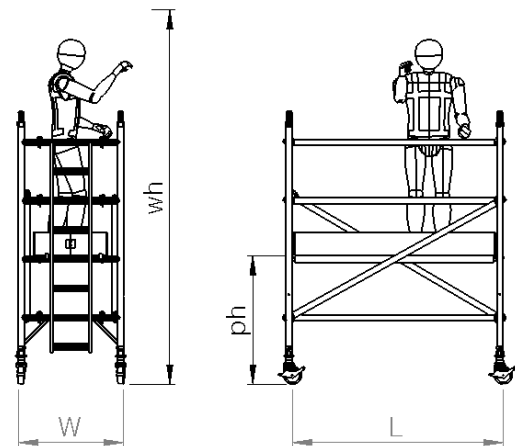
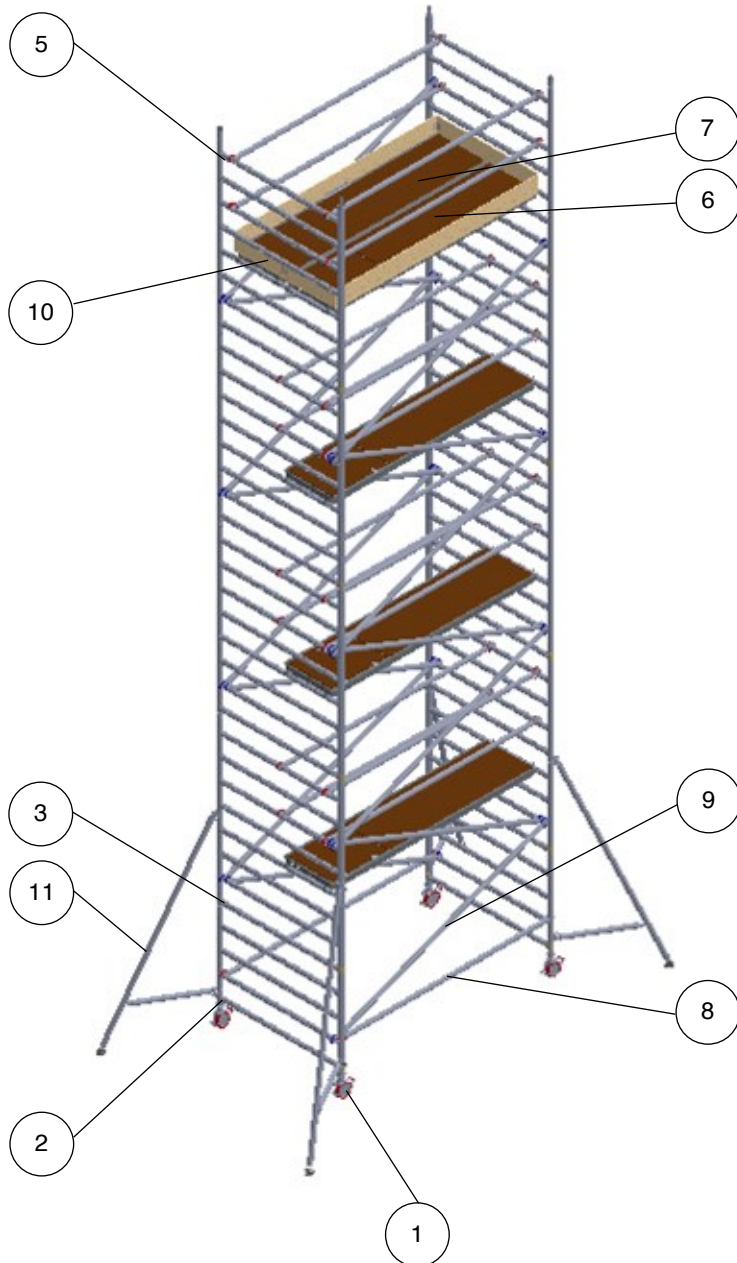

### Technical information:

Base Dimensions:	(L)2.5m X (W)1.45m
Maximum Platform Height (ph):	8.2m
Maximum Working Height (wh):	10.2m
Maximum Working Load Per Platform:	275kg
Maximum Working Load Per Tower: (including tower weight)	950kg
Weight:	283.4kg

Mr Plant Hire  
120 Hertford Road Enfield  
London EN3 5AX

☎ 020 8351 3434  
✉ info@mrplanthire.co.uk





# SERVICE YOU CAN TRUST

<b>Double Width Tower</b> 2.5m Long x 1.45m Wide	<b>Working Height</b> 10.7m	<b>Platform Height</b> 8.7m
---	--------------------------------	--------------------------------

## Tower Components

Item	Description	Quantity
1	150mm Locking Caster	4
2	Adjustable Leg 500mm	4
3	1m 4 Rung Frame	0
4	1.5m 6 Rung Frame	2
5	2m 8 Rung Frame	8
6	2.5m Trapdoor Platform	4
7	2.5m Fixed Platform	1
8	2.5m Horizontal Brace	18
9	2.7m Diagonal Brace	16
10	Complete Toe Board Set	1
11	S1 Stabiliser	0
12	S2 Stabiliser	4
13	Instruction Manual & EN1004:-1:2020 certificate of conformity	1

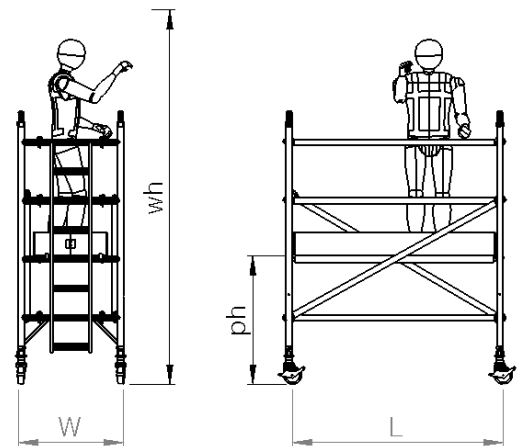
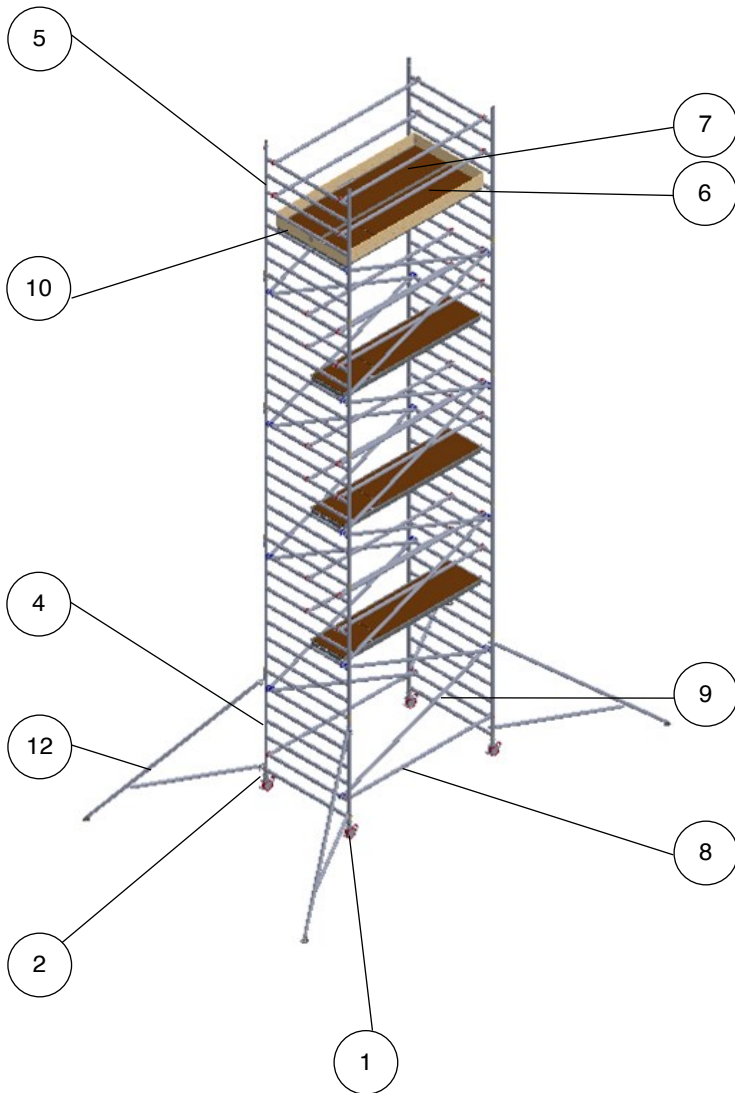

### Technical information:

Base Dimensions:	(L)2.5m X (W)1.45m
Maximum Platform Height (ph):	8.7m
Maximum Working Height (wh):	10.7m
Maximum Working Load Per Platform:	275kg
Maximum Working Load Per Tower: (including tower weight)	950kg
Weight:	297.2kg

Mr Plant Hire  
120 Hertford Road Enfield  
London EN3 5AX

☎ 020 8351 3434  
✉ info@mrplanthire.co.uk







# SERVICE YOU CAN TRUST

<b>Double Width Tower</b> 2.5m Long x 1.45m Wide	<b>Working Height</b> 11.2m	<b>Platform Height</b> 9.2m
---	--------------------------------	--------------------------------

## Tower Components

Item	Description	Quantity
1	150mm Locking Caster	4
2	Adjustable Leg 500mm	4
3	1m 4 Rung Frame	0
4	1.5m 6 Rung Frame	0
5	2m 8 Rung Frame	10
6	2.5m Trapdoor Platform	5
7	2.5m Fixed Platform	1
8	2.5m Horizontal Brace	22
9	2.7m Diagonal Brace	17
10	Complete Toe Board Set	1
11	S1 Stabiliser	0
12	S2 Stabiliser	4
13	Instruction Manual & EN1004:-1:2020 certificate of conformity	1

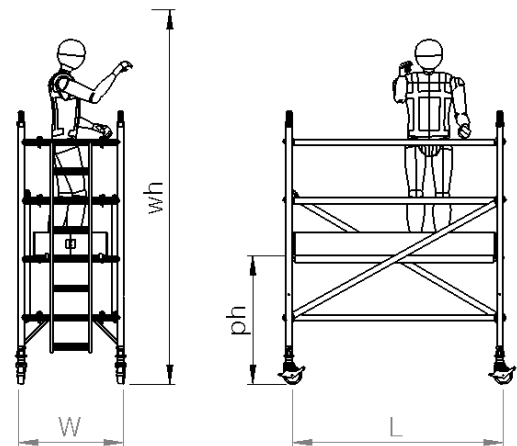
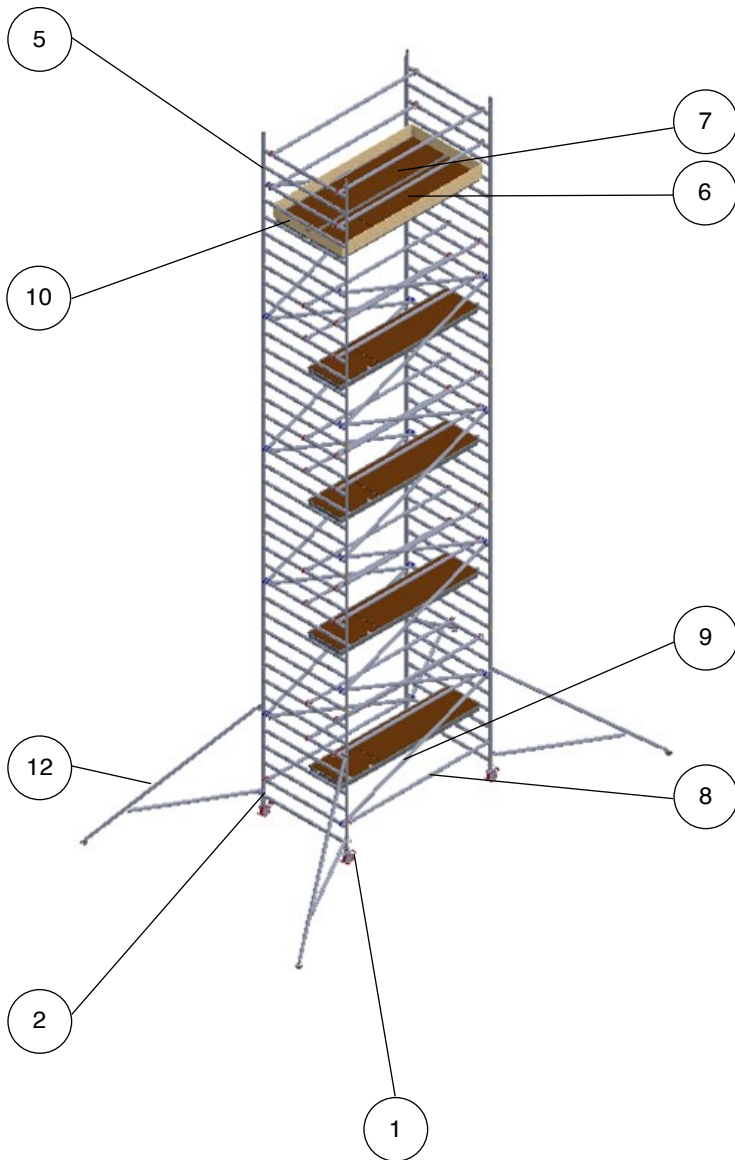

### Technical information:

Base Dimensions:	(L)2.5m X (W)1.45m
Maximum Platform Height (ph):	9.2m
Maximum Working Height (wh):	11.2m
Maximum Working Load Per Platform:	275kg
Maximum Working Load Per Tower: (including tower weight)	950kg
Weight:	329kg

Mr Plant Hire  
120 Hertford Road Enfield  
London EN3 5AX

☎ 020 8351 3434  
✉ info@mrplanthire.co.uk

BS 8620:2016  
TM1005  
testandresearch.org



# SERVICE YOU CAN TRUST

<b>Double Width Tower</b> 2.5m Long x 1.45m Wide	<b>Working Height</b> 11.7m	<b>Platform Height</b> 9.7m
---	--------------------------------	--------------------------------

## Tower Components

Item	Description	Quantity
1	150mm Locking Caster	4
2	Adjustable Leg 500mm	4
3	1m 4 Rung Frame	2
4	1.5m 6 Rung Frame	2
5	2m 8 Rung Frame	8
6	2.5m Trapdoor Platform	5
7	2.5m Fixed Platform	1
8	2.5m Horizontal Brace	22
9	2.7m Diagonal Brace	18
10	Complete Toe Board Set	1
11	S1 Stabiliser	0
12	S2 Stabiliser	4
13	Instruction Manual & EN1004:-1:2020 certificate of conformity	1

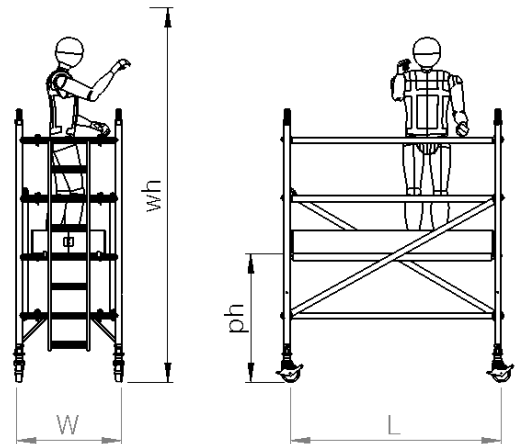
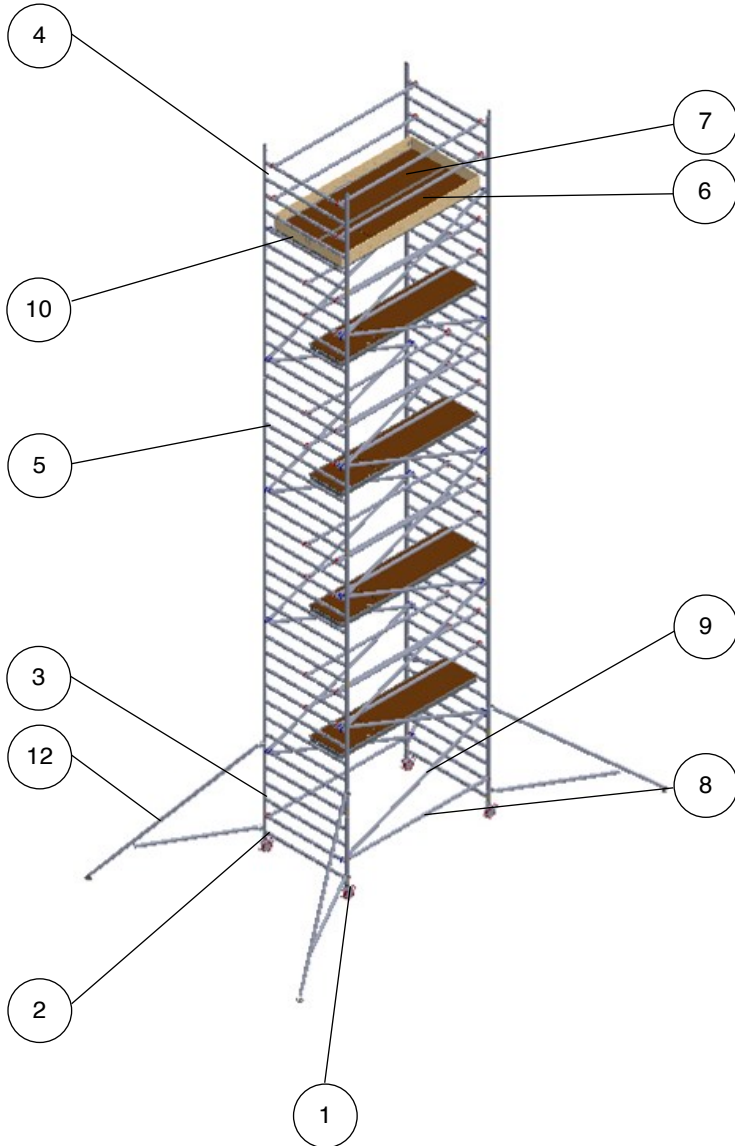

### Technical information:

Base Dimensions:	(L)2.5m X (W)1.45m
Maximum Platform Height (ph):	9.7m
Maximum Working Height (wh):	11.7m
Maximum Working Load Per Platform:	275kg
Maximum Working Load Per Tower: (including tower weight)	950kg
Weight:	336.9kg

Mr Plant Hire  
120 Hertford Road Enfield  
London EN3 5AX

☎ 020 8351 3434  
✉ info@mrplanthire.co.uk





# SERVICE YOU CAN TRUST

<b>Double Width Tower</b> 2.5m Long x 1.45m Wide	<b>Working Height</b> 12.2m	<b>Platform Height</b> 10.2m
---	--------------------------------	---------------------------------

## Tower Components

Item	Description	Quantity
1	150mm Locking Caster	4
2	Adjustable Leg 500mm	4
3	1m 4 Rung Frame	2
4	1.5m 6 Rung Frame	0
5	2m 8 Rung Frame	10
6	2.5m Trapdoor Platform	5
7	2.5m Fixed Platform	1
8	2.5m Horizontal Brace	22
9	2.7m Diagonal Brace	19
10	Complete Toe Board Set	1
11	S1 Stabiliser	0
12	S2 Stabiliser	4
13	Instruction Manual & EN1004:-1:2020 certificate of conformity	1

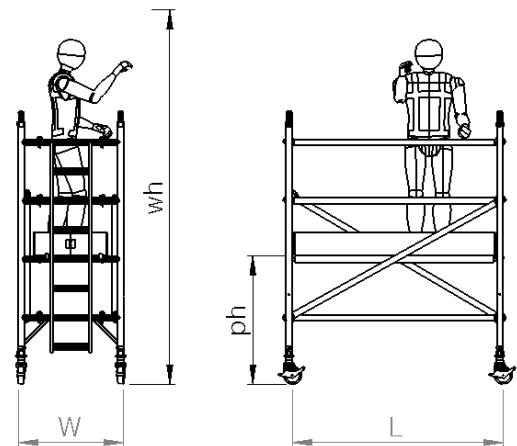
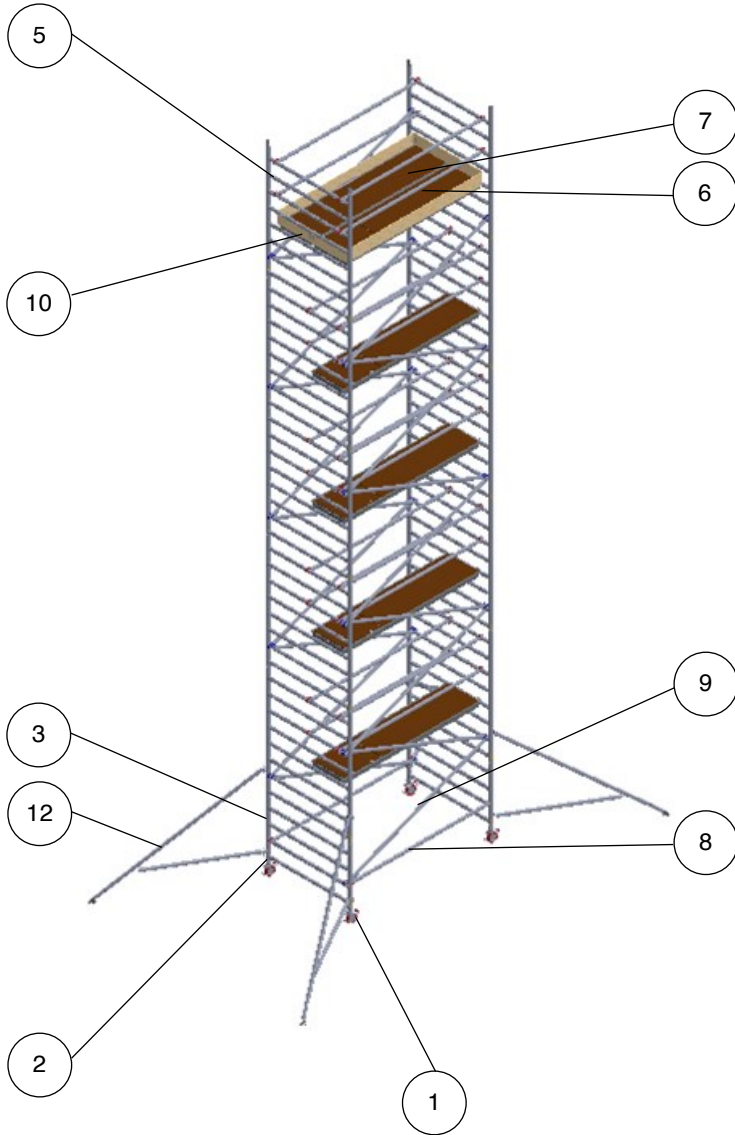

### Technical information:

Base Dimensions:	(L)2.5m X (W)1.45m
Maximum Platform Height (ph):	10.2m
Maximum Working Height (wh):	12.2m
Maximum Working Load Per Platform:	275kg
Maximum Working Load Per Tower: (including tower weight)	950kg
Weight:	343.2kg

Mr Plant Hire  
120 Hertford Road Enfield  
London EN3 5AX

☎ 020 8351 3434  
✉ info@mrplanthire.co.uk





# SERVICE YOU CAN TRUST

<b>Double Width Tower</b> 2.5m Long x 1.45m Wide	<b>Working Height</b> 12.7m	<b>Platform Height</b> 10.7m
---	--------------------------------	---------------------------------

## Tower Components

Item	Description	Quantity
1	150mm Locking Caster	4
2	Adjustable Leg 500mm	4
3	1m 4 Rung Frame	0
4	1.5m 6 Rung Frame	2
5	2m 8 Rung Frame	10
6	2.5m Trapdoor Platform	5
7	2.5m Fixed Platform	1
8	2.5m Horizontal Brace	22
9	2.7m Diagonal Brace	20
10	Complete Toe Board Set	1
11	S1 Stabiliser	0
12	S2 Stabiliser	4
13	Instruction Manual & EN1004:-1:2020 certificate of conformity	1

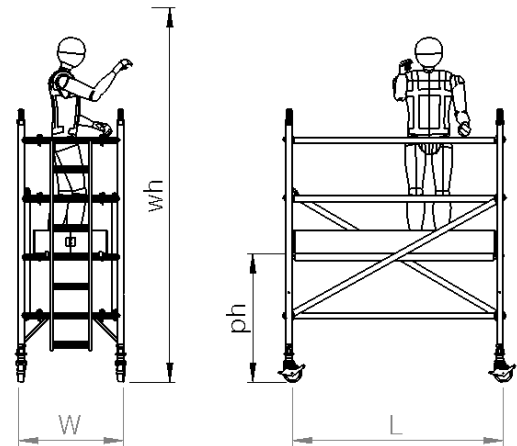
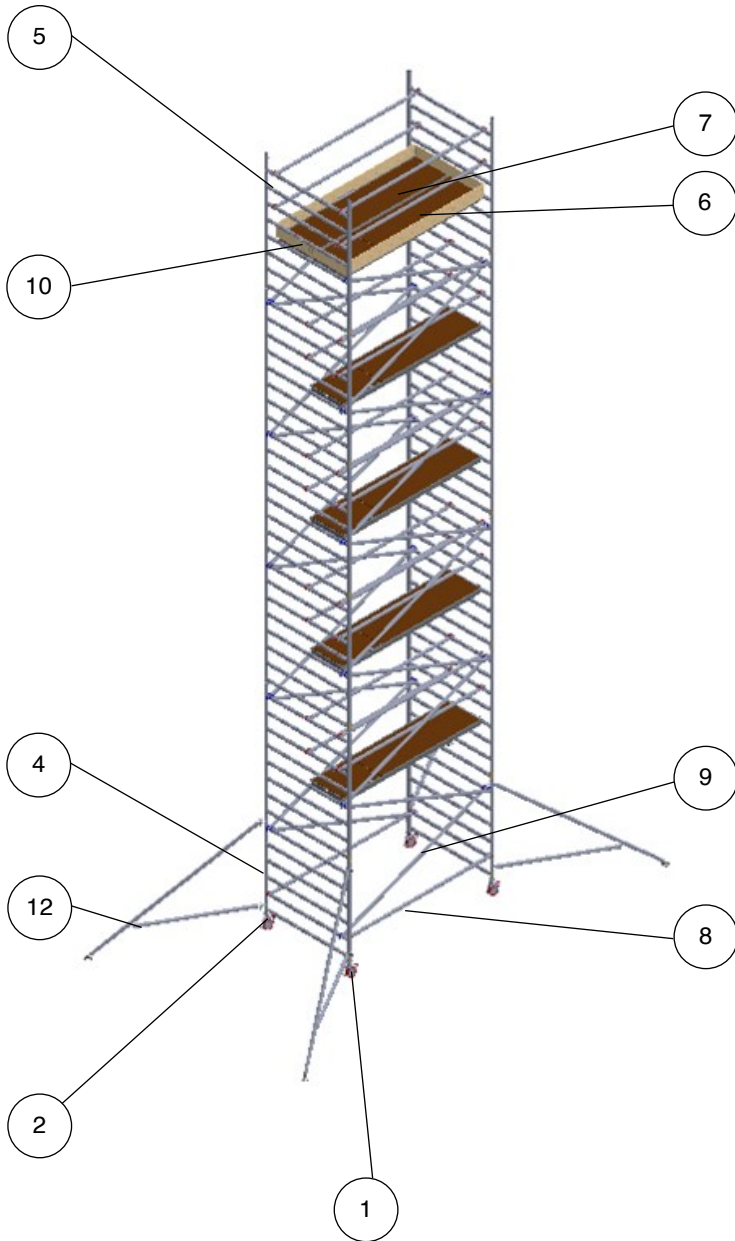

### Technical information:

Base Dimensions:	(L)2.5m X (W)1.45m
Maximum Platform Height (ph):	10.7m
Maximum Working Height (wh):	12.7m
Maximum Working Load Per Platform:	275kg
Maximum Working Load Per Tower: (including tower weight)	950kg
Weight:	349.8kg

Mr Plant Hire  
120 Hertford Road Enfield  
London EN3 5AX

☎ 020 8351 3434  
✉ info@mrplanthire.co.uk

BS 8620:2016  
TM1005  
testandresearch.org

<b>Double Width Tower</b> 2.5m Long x 1.45m Wide	<b>Working Height</b> 13.2m	<b>Platform Height</b> 11.2m
---	--------------------------------	---------------------------------

## Tower Components

Item	Description	Quantity
1	150mm Locking Caster	4
2	Adjustable Leg 500mm	4
3	1m 4 Rung Frame	0
4	1.5m 6 Rung Frame	0
5	2m 8 Rung Frame	10
6	2.5m Trapdoor Platform	6
7	2.5m Fixed Platform	1
8	2.5m Horizontal Brace	26
9	2.7m Diagonal Brace	21
10	Complete Toe Board Set	1
11	S1 Stabiliser	0
12	S2 Stabiliser	4
13	Instruction Manual & EN1004:-1:2020 certificate of conformity	1

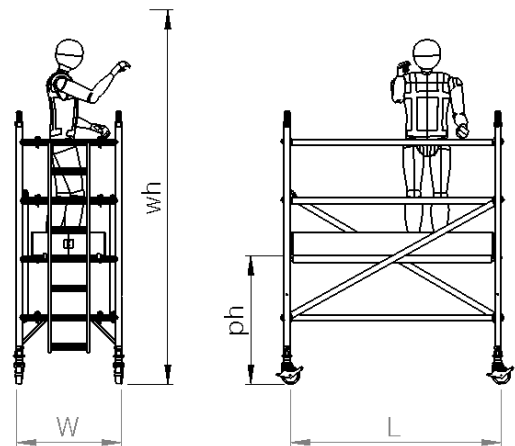
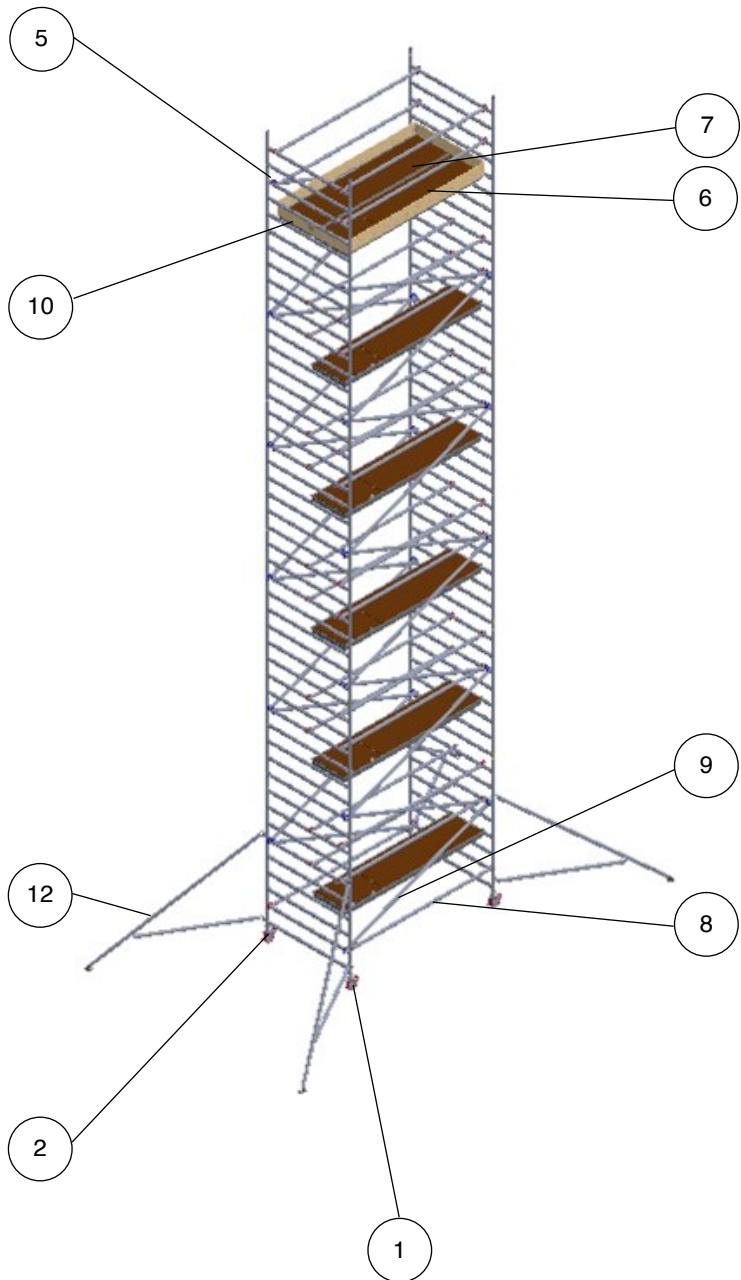

### Technical information:

Base Dimensions:	(L)2.5m X (W)1.45m
Maximum Platform Height (ph):	11.2m
Maximum Working Height (wh):	13.2m
Maximum Working Load Per Platform:	275kg
Maximum Working Load Per Tower: (including tower weight)	950kg
Weight:	381.6kg



# SERVICE YOU CAN TRUST

<b>Double Width Tower</b> 2.5m Long x 1.45m Wide	<b>Working Height</b> 13.7m	<b>Platform Height</b> 11.7m
---	--------------------------------	---------------------------------

## Tower Components

Item	Description	Quantity
1	150mm Locking Caster	4
2	Adjustable Leg 500mm	4
3	1m 4 Rung Frame	2
4	1.5m 6 Rung Frame	2
5	2m 8 Rung Frame	10
6	2.5m Trapdoor Platform	6
7	2.5m Fixed Platform	1
8	2.5m Horizontal Brace	26
9	2.7m Diagonal Brace	22
10	Complete Toe Board Set	1
11	S1 Stabiliser	0
12	S2 Stabiliser	4
13	Instruction Manual & EN1004:-1:2020 certificate of conformity	1

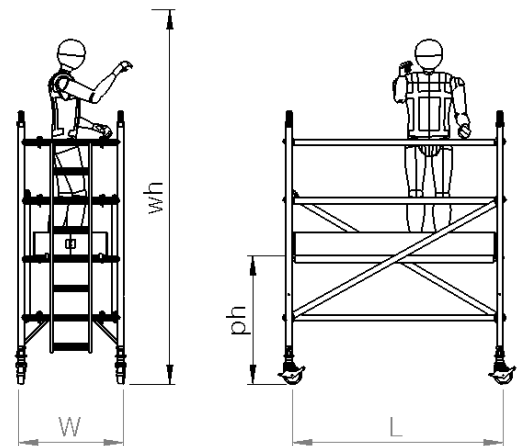
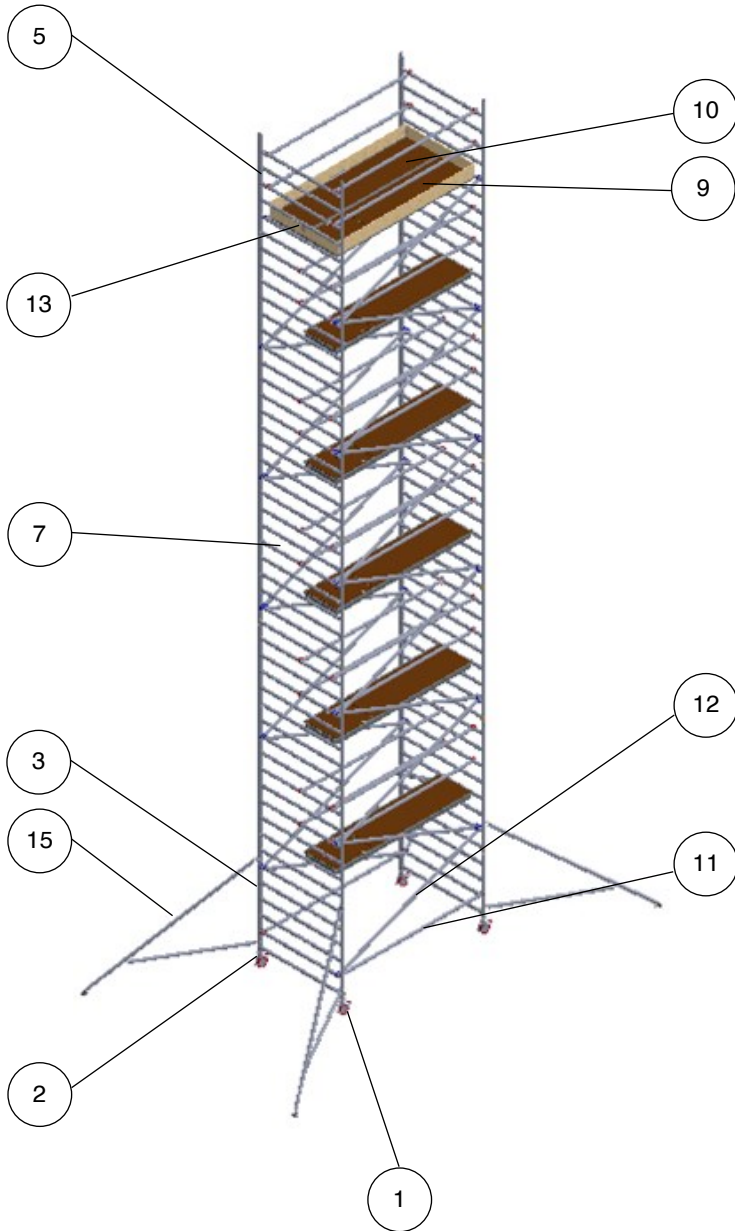

### Technical information:

Base Dimensions:	(L)2.5m X (W)1.45m
Maximum Platform Height (ph):	11.7m
Maximum Working Height (wh):	13.7m
Maximum Working Load Per Platform:	275kg
Maximum Working Load Per Tower: (including tower weight)	950kg
Weight:	389.5kg

Mr Plant Hire  
120 Hertford Road Enfield  
London EN3 5AX

☎ 020 8351 3434  
✉ info@mrplanthire.co.uk





# SERVICE YOU CAN TRUST

<b>Double Width Tower</b> 2.5m Long x 1.45m Wide	<b>Working Height</b> 14.2m	<b>Platform Height</b> 12.2m
---	--------------------------------	---------------------------------

## Tower Components

Item	Description	Quantity
1	150mm Locking Caster	4
2	Adjustable Leg 500mm	4
3	1m 4 Rung Frame	2
4	1.5m 6 Rung Frame	0
5	2m 8 Rung Frame	12
6	2.5m Trapdoor Platform	6
7	2.5m Fixed Platform	1
8	2.5m Horizontal Brace	26
9	2.7m Diagonal Brace	23
10	Complete Toe Board Set	1
11	S1 Stabiliser	0
12	S2 Stabiliser	4
13	Instruction Manual & EN1004:-1:2020 certificate of conformity	1

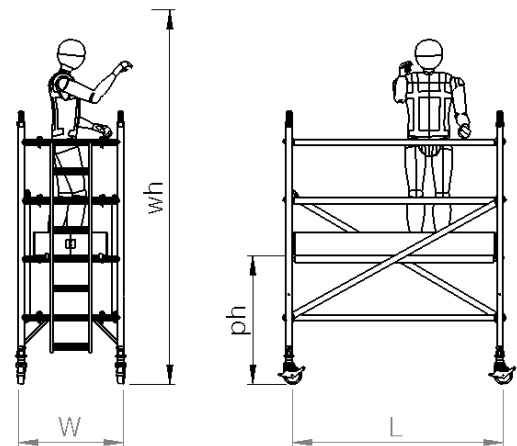
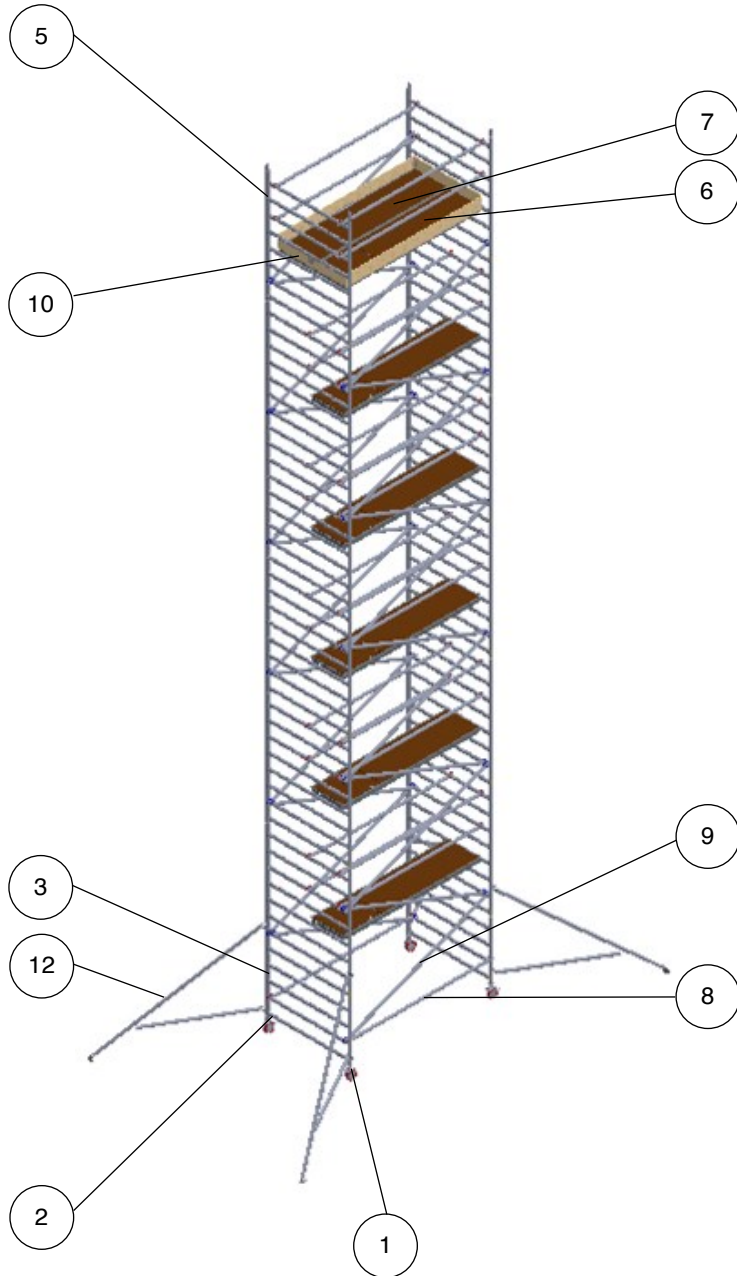

### Technical information:

Base Dimensions:	(L)2.5m X (W)1.45m
Maximum Platform Height (ph):	12.2m
Maximum Working Height (wh):	14.2m
Maximum Working Load Per Platform:	275kg
Maximum Working Load Per Tower: (including tower weight)	950kg
Weight:	395.8kg

**Mr Plant Hire**  
120 Hertford Road Enfield  
London EN3 5AX

☎ 020 8351 3434  
✉ info@mrplanthire.co.uk

BS 8620:2016  
TM1005  
testandresearch.org